

IQ

Помпи центробежни с периферно работно колело

Clean water
 Domestic use
 Industrial use



PERFORMANCE RANGE

- Flow rate up to **50 l/min** (3.0 m³/h)
- Head up to **70 m**

APPLICATION LIMITS

- Manometric suction lift up to **8 m**
- Liquid temperature between **-10 °C** and **+90 °C**
- Ambient temperature between **-10 °C** and **+40 °C** (+45 °C for IQ 05)
- Max. working pressure:
 - **6 bar** for IQ 05, IQ 07
 - **10 bar** for IQ 1000
- Continuous service **S1**

CONSTRUCTION AND SAFETY STANDARDS

EN 60335-1
IEC 60335-1
CEI 61-150

EN 60034-1
IEC 60034-1
CEI 2-3



CHARACTERISTIC CURVES AND PERFORMANCE DATA

50 Hz | n = 2900 min⁻¹ | HS = 0 m

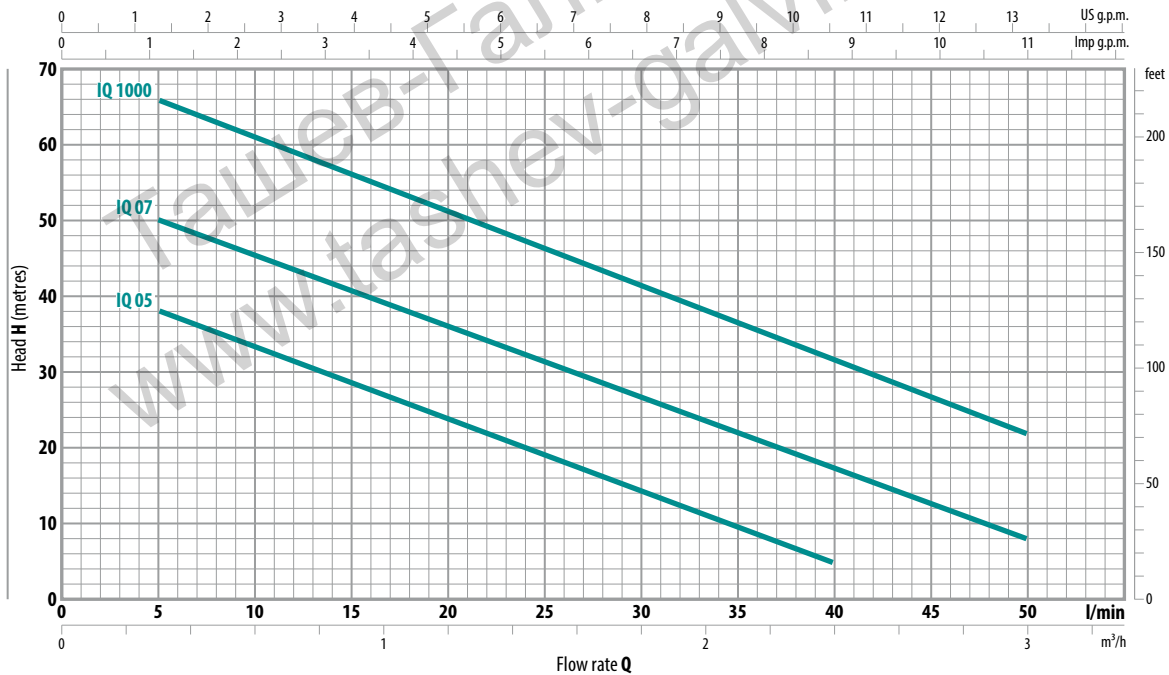

MODEL		POWER (P ₂)		Q	Flow rate											
Single-phase	Three-phase	kW	HP		m ³ /h	0	0.3	0.6	0.9	1.2	1.5	1.8	2.1	2.4	3.0	
				l/min	0	5	10	15	20	25	30	35	40	50		
IQ 05M	IQ 05	0.37	0.50	H metres	40	38	33.5	29	24	19.5	15	10	5			
IQ 07M	IQ 07	0.55	0.75		55	50	45.5	40.5	36	31	27	22	17	8		
IQ 1000M	IQ 1000	0.75	1		70	66	61	56	51	46	41	36.5	31	22		

Q = Flow rate
 H = Total manometric head
 HS = Suction height

Tolerance of characteristic curves in compliance with EN ISO 9906 Grade 3B.

INSTALLATION AND USE

Suitable for use with clean water that does not contain abrasive particles and with liquids that are not chemically aggressive towards the materials from which the pump is made.

The hydraulic characteristics of these pumps, coupled with their compactness, makes them suitable for use in both domestic and industrial applications.

The pump should be installed in an enclosed environment or sheltered from inclement weather.

CONSTRUCTION CHARACTERISTICS

PUMP BODY	Cast iron with an Epoxy Electro Coating treatment, with threaded ports in compliance with ISO 228/1
IMPELLER	Brass with peripheral radial vanes
MOTOR SHAFT	Stainless steel EN 10088-3 - 1.4104
MECHANICAL SEAL	IQ05, IQ07: Ceramic - Graphite - NBR IQ1000: Silicon carbide - Graphite - NBR
ELECTRIC MOTOR	The three-phase pumps are fitted with high performance motors up to P2=0.55kW in class IE2 and from P2=0.60kW in class IE3 (IEC 60034-30)

DIMENSIONS AND WEIGHT

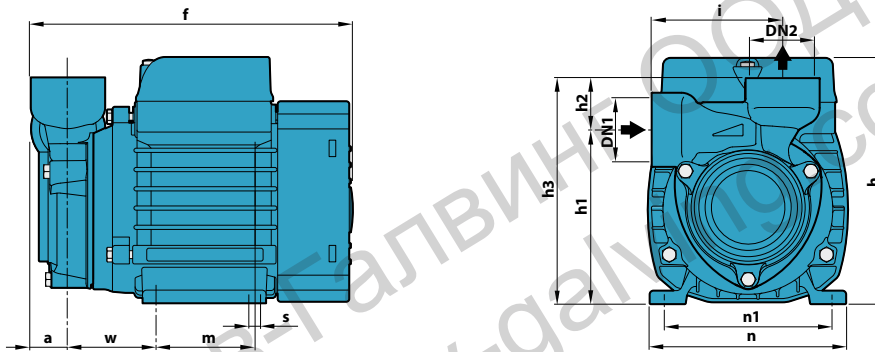

MODEL		PORTS		DIMENSIONS mm													kg	
Single-phase	Three-phase	DN1	DN2	a	f	h	h1	h2	h3	i	m	n	n1	w	s	1~	3~	
IQ 05M	IQ 05	1"	1"	22	190	145	101	30	131	76	55	118	93-100	53	7	5.1	5.1	
IQ 07M	IQ 07			220	152	113	143		78	80	120	100	7.0			6.2		
IQ 1000M	IQ 1000			255	180*	121	151		83	90	138	112	62			9.7	9.6	

(*) h=199 mm for single phase versions at 110 V

ABSORPTION

MODEL	VOLTAGE		
Single-phase	230 V	240 V	110 V
IQ 05M	2.6 A	2.4 A	5.2 A
IQ 07M	3.7 A	3.4 A	7.4 A
IQ 1000M	5.2 A	4.8 A	10.5 A

MODEL	VOLTAGE				
Three-phase	230 V	400 V	690 V	240 V	415 V
IQ 05	2.0 A	1.15 A	-	1.9 A	1.1 A
IQ 07	3.0 A	1.7 A	-	2.8 A	1.6 A
IQ 1000	3.8 A	2.2 A	-	3.3 A	1.9 A

PALLETIZATION

MODEL		GROUPAGE	CONTAINER
Single-phase	Three-phase	n. pumps	n. pumps
IQ 05M	IQ 05	256	352
IQ 07M	IQ 07	200	240
IQ 1000M	IQ 1000	102	170